

CSCS  
Swiss National Supercomputing Centre

Ing. Mario Valle  
CSCS Data Analysis Group

An introduction to the  
molecular visualization  
toolkit STM4

---

---

---

---

---

---

---

---

Agenda

Why STM4?

STM4 architecture

AVS/Express concepts

STM4 modules overview

STM4 quick tour

---

---

---

---

---

---

---

---

Agenda

Why STM4?

STM4 architecture

AVS/Express concepts

STM4 modules overview

STM4 quick tour

---

---

---

---

---

---

---

---

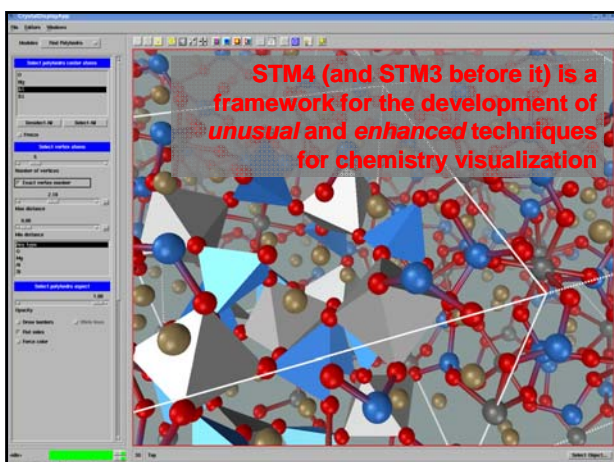

---

---

---

---

---

---

---

---

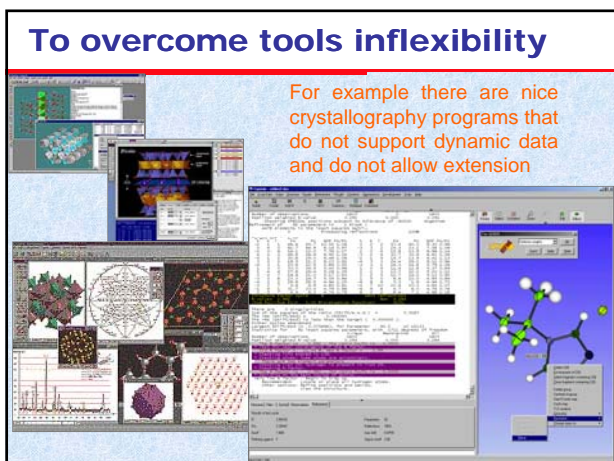

---

---

---

---

---

---

---

---

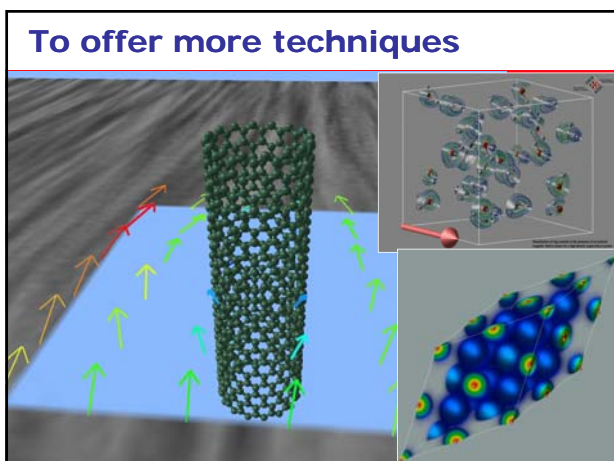

---

---

---

---

---

---

---

---

## To enhance existing techniques

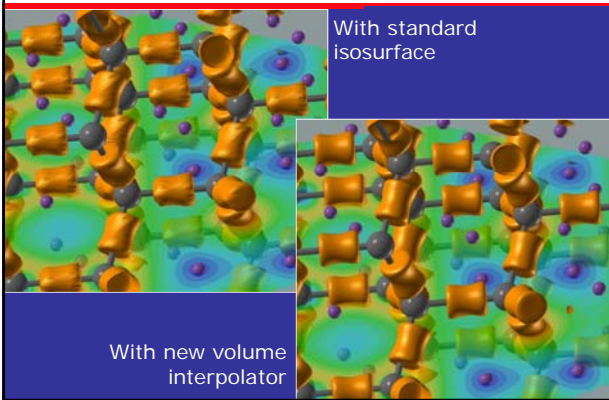

---

---

---

---

---

---

---

---

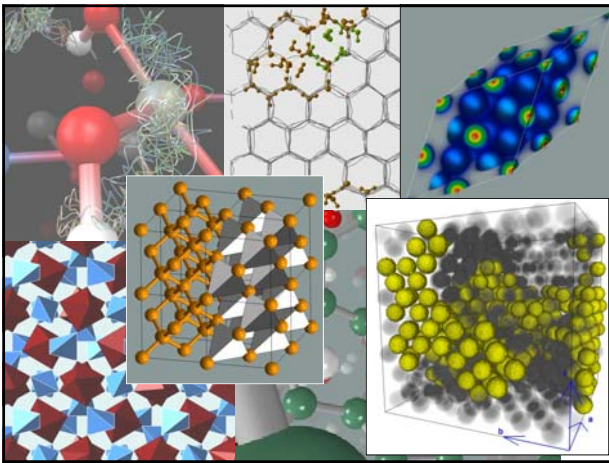

---

---

---

---

---

---

---

---

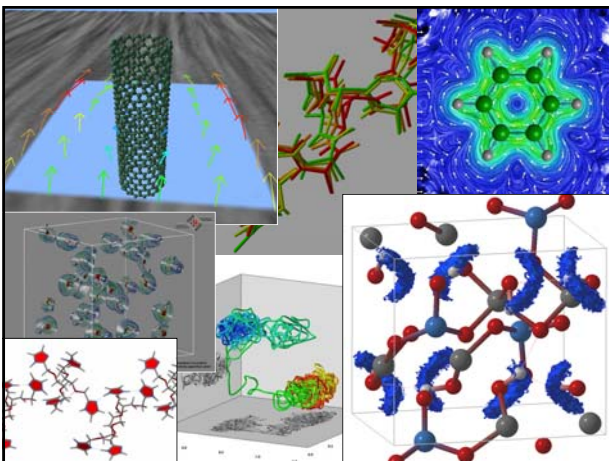

---

---

---

---

---

---

---

---

## Hydrogen atoms motion in topaz

The atom traces representation (below) is too detailed and contains a lot of unnecessary information

Simulation by Sergey Churakov – PSI

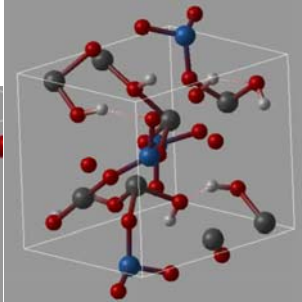
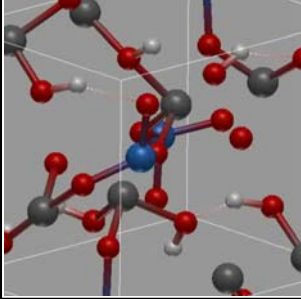

Motion represented by occupancy "clouds" shows better the overall movement of hydrogen atoms

---

---

---

---

---

---

---

---

## Argon condensation

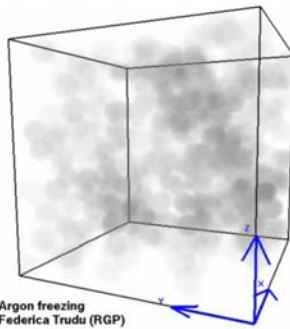

Argon freezing  
Federica Trudu (RGP)

Simulation by Federica Trudu – ETH Zürich

Classical molecular dynamics simulation of argon atoms freezing. Here a scalar value associated to each atom represents its "status". Atoms approaching the freezing threshold for this parameter turn less and less transparent. Frozen atoms are rendered as yellow spheres

The "clouds" provide context for the frozen atoms visualization and highlight the transition between fluid and frozen status

ETH ZÜRICH

STM4 introduction - Mario Valle - 06/11/08

CSGS

## Argon condensation (2<sup>nd</sup> try)

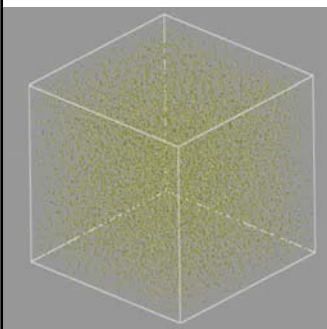

- More refined computation
- Less time for nice rendering
- Titles and legends on the slide, not on the movie

ETH ZÜRICH

STM4 introduction - Mario Valle - 06/11/08

CSGS

---

---

---

---

---

---

---

---

## Simulated X-Ray diffraction

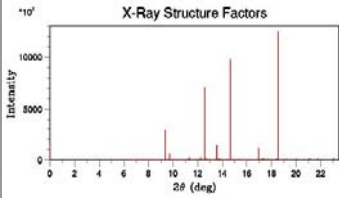
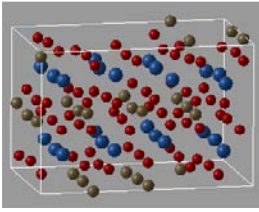

Data from prof. A. Oganov – ETH Zürich

Usage of computed simplified X-Ray structure factors to detect structural changes

---

---

---

---

---

---

---

---

## And a recent example

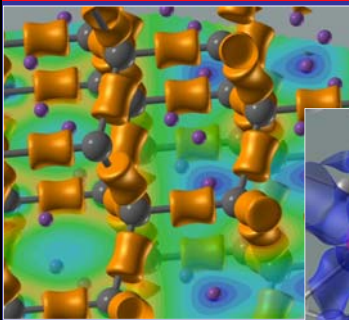

“Study of the diffusion of vacancies in solid LiAl alloys”

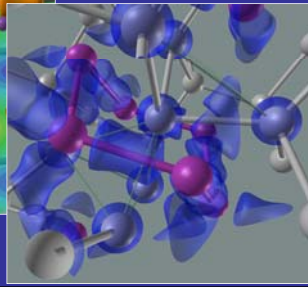

C. Cucinotta – RGP Lugano

---

---

---

---

---

---

---

---

## Which is the difference?

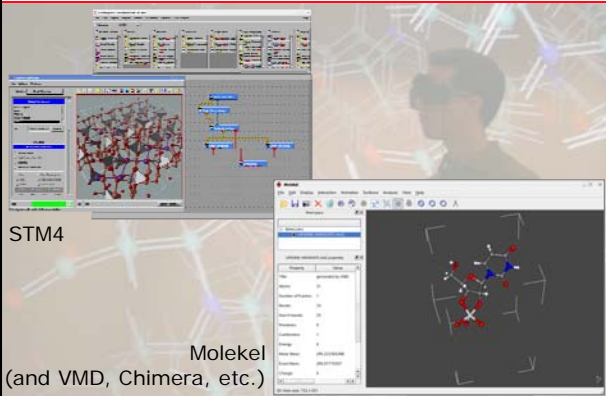

STM4

Molekel  
(and VMD, Chimera, etc.)

---

---

---

---

---

---

---

---

## What STM4 is not

- **A complete chemistry visualization tool**
  - It grows depending on user requests. If something is not requested, it is not be added.
  - Remember, STM4 goal is not to replace existing tools
- **A simple, end user tool**
  - It is more a LEGO construction box
  - More power and flexibility comes at the expense of no point-and-click interface
- **A tool for a specific chemistry field (biochemistry, MD, crystallography, etc.)**
  - Again functionalities depend on the requests
  - But it is precisely its goal to be cross-field



---

---

---

---

---

---

---

---

## STM4 approach is effective

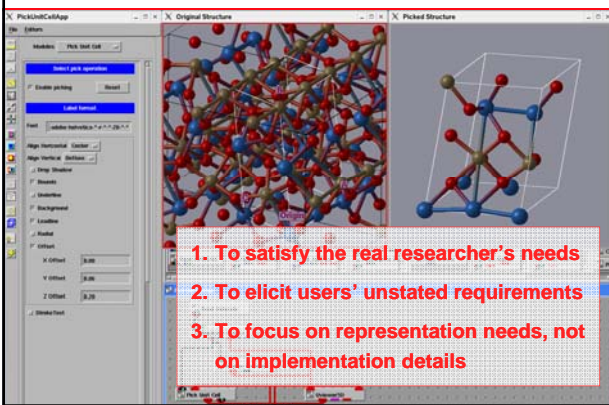

---

---

---

---

---

---

---

---

## Agenda

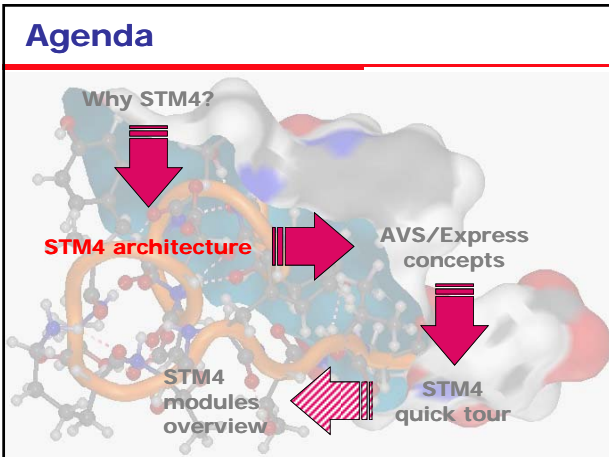

---

---

---

---

---

---

---

---

## STM4 architecture

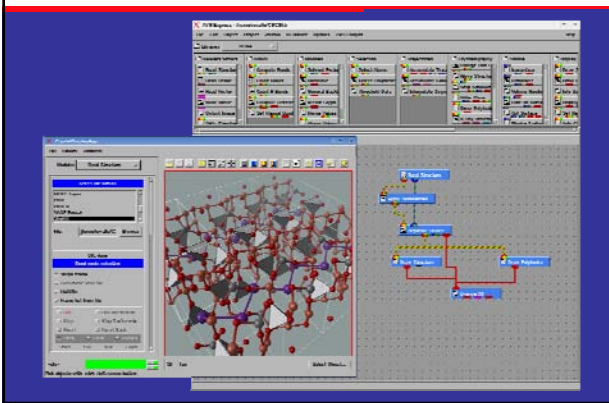

---

---

---

---

---

---

---

---

---

---

## STM4 modules

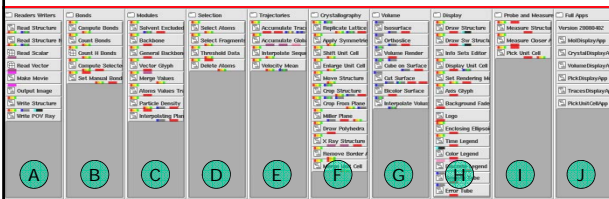

- A. Readers and writers: chemical formats and screenshots
- B. Bonds related modules; compute, count and edit
- C. Modules that compute various derived structures
- D. Atoms selection by various criteria
- E. Trajectory related modules
- F. Crystallography support modules: symmetries, replications, etc.
- G. Visualization of volumetric data like Gaussian cubes
- H. Structure display and related graphical objects
- I. Probe, interaction and measurements
- J. Ready to run applications (plus display of the STM4 version)

---

---

---

---

---

---

---

---

---

---

## STM4 application example

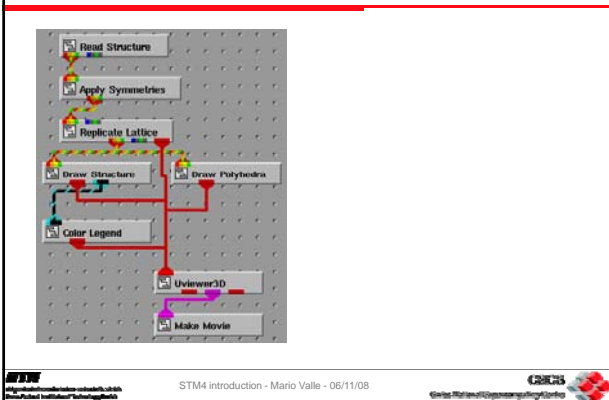

---

---

---

---

---

---

---

---

---

---

## STM4 application example

STM4 introduction - Mario Valle - 06/11/08

---

---

---

---

---

---

---

---

## AVS/Express behind the scenes

AVS/Express interface showing a 3D molecular model and a workflow diagram.

---

---

---

---

---

---

---

---

## Agenda

Why STM4?  
STM4 architecture  
STM4 modules overview  
STM4 quick tour  
AVS/Express concepts

---

---

---

---

---

---

---

---

## What is AVS/Express?

A development environment...

...for 3D visualization applications

...object oriented

...based on a visual programming paradigm

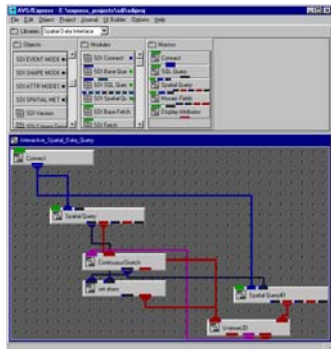

STM4 introduction - Mario Valle - 06/11/08

---

---

---

---

---

---

---

---

---

---

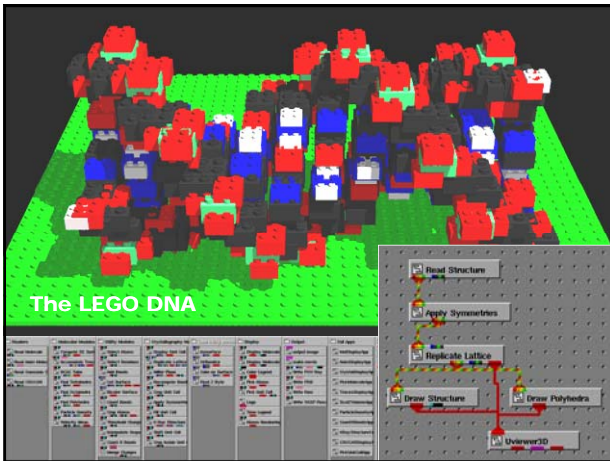

---

---

---

---

---

---

---

---

---

---

## Viz techniques

More than 500 visualization techniques available

Readers available for a broad range of file formats

AVS/Express prototyping support helps finding the most useful technique

Any technique can be adapted to suit specific user requirements



---

---

---

---

---

---

---

---

---

---

## AVS/Express components

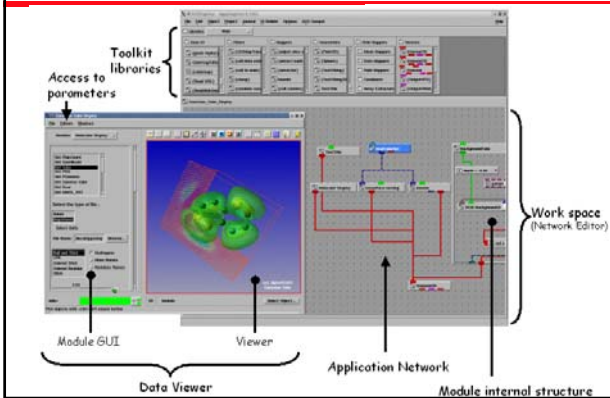

---

---

---

---

---

---

---

---

## Data Viewer

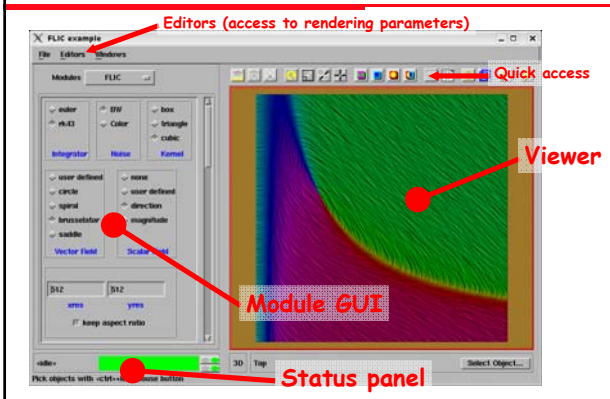

---

---

---

---

---

---

---

---

## Default library

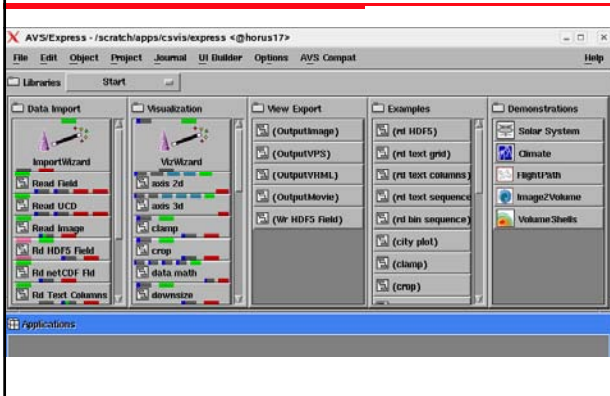

---

---

---

---

---

---

---

---



## Dataflow architecture

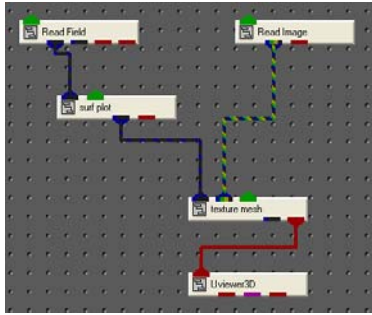

STM4 introduction - Mario Valle - 06/11/08



---

---

---

---

---

---

---

---

## Dataflow architecture

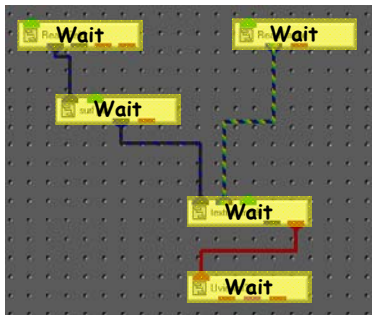

STM4 introduction - Mario Valle - 06/11/08



---

---

---

---

---

---

---

---

## Dataflow architecture

Enter filename

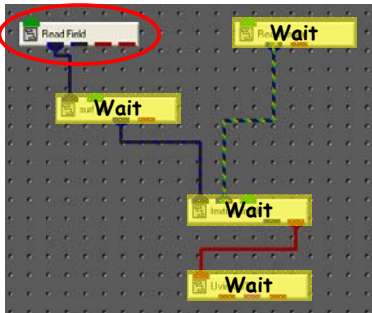

STM4 introduction - Mario Valle - 06/11/08



---

---

---

---

---

---

---

---

## Dataflow architecture

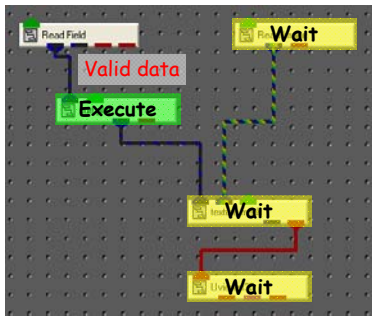

STM4 introduction - Mario Valle - 06/11/08



---

---

---

---

---

---

---

---

## Dataflow architecture

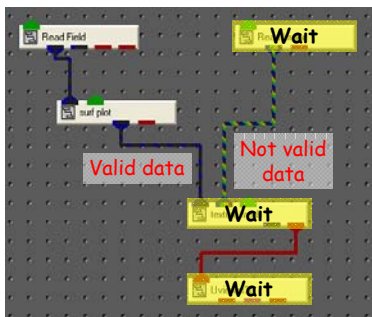

STM4 introduction - Mario Valle - 06/11/08



---

---

---

---

---

---

---

---

## Dataflow architecture

Enter filename

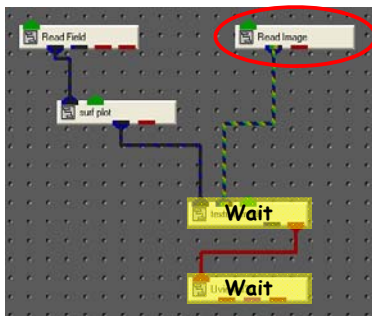

STM4 introduction - Mario Valle - 06/11/08



---

---

---

---

---

---

---

---

## Dataflow architecture

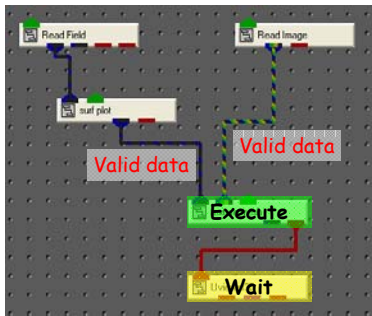

STM4 introduction - Mario Valle - 06/11/08



---

---

---

---

---

---

---

---

## Dataflow architecture

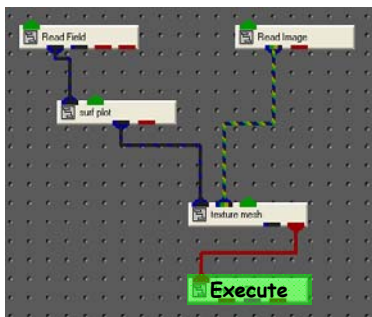

STM4 introduction - Mario Valle - 06/11/08



---

---

---

---

---

---

---

---

## The result of this application

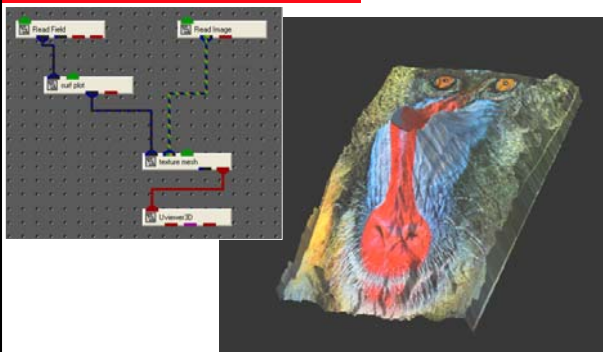

STM4 introduction - Mario Valle - 06/11/08



---

---

---

---

---

---

---

---



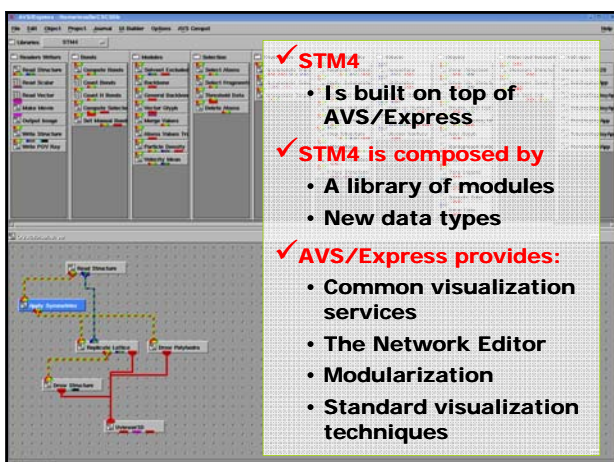

✓ **STM4**

- Is built on top of AVS/Express

✓ **STM4 is composed by**

- A library of modules
- New data types

✓ **AVS/Express provides:**

- Common visualization services
- The Network Editor
- Modularization
- Standard visualization techniques

---

---

---

---

---

---

---

---

### Access to the STM4 library

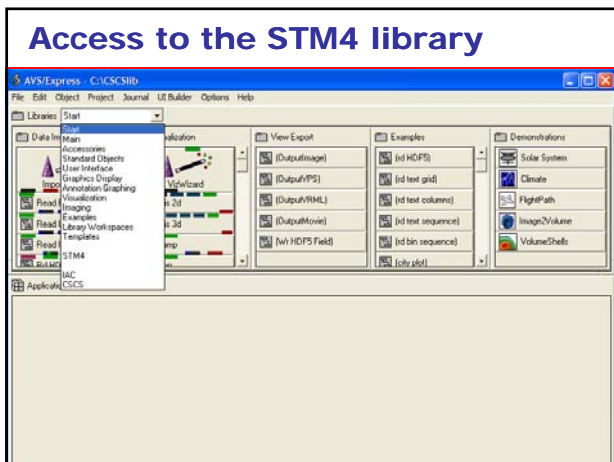

---

---

---

---

---

---

---

---

### STM4 modules

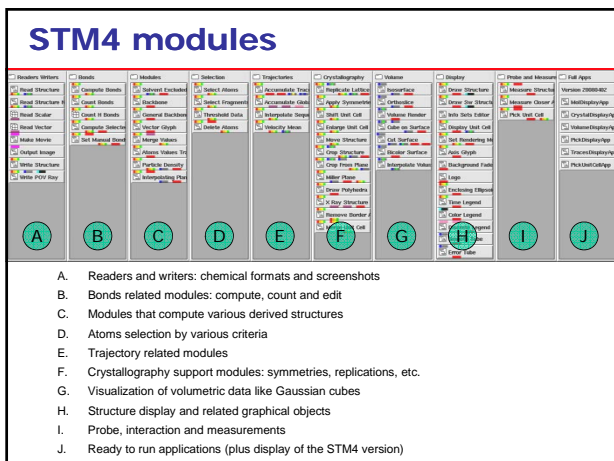

- A. Readers and writers: chemical formats and screenshots
- B. Bonds related modules: compute, count and edit
- C. Modules that compute various derived structures
- D. Atoms selection by various criteria
- E. Trajectory related modules
- F. Crystallography support modules: symmetries, replications, etc.
- G. Visualization of volumetric data like Gaussian cubes
- H. Structure display and related graphical objects
- I. Probe, interaction and measurements
- J. Ready to run applications (plus display of the STM4 version)

---

---

---

---

---

---

---

---

## STM4 applications

- The concepts are exactly the same as AVS/Express
- An application can use STM4 and standard AVS/Express modules together
- STM4 uses all AVS/Express types plus some of its own
- For common tasks STM4 provides some pre-build applications

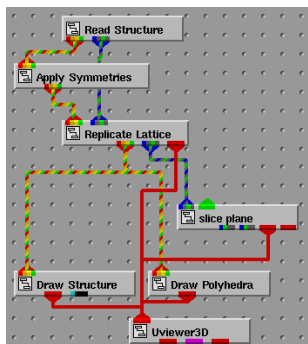

STM4 introduction - Mario Valle - 06/11/08



---

---

---

---

---

---

---

---

## STM4 data types

Molecular Data Type

Standard AVS Field

Display Parameters

Geometries

Screen Image

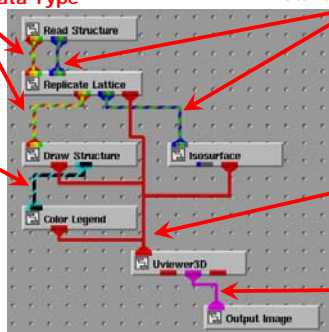

STM4 introduction - Mario Valle - 06/11/08



---

---

---

---

---

---

---

---

## STM4 resources

- **STM4 main pages**  
<http://www.cscs.ch/~mvalle/STM4/>
- **The STM4 modules documentation**  
<http://www.cscs.ch/~mvalle/STM4/doc/STM4/>
- **STM4 download**  
<http://www.cscs.ch/~mvalle/STM4/download.html>
- **The original STM3 paper (are using STM4? Please cite it)**  
M. Valle, **STM3: a chemistry visualization platform**,  
*Zeitschrift für Kristallographie*, vol. 220, no. 5-6, pp. 585-588, 2005
- **A user level AVS/Express course**  
<http://www.cscs.ch/~mvalle/AVS/introduction-to-xp.html>
- **A (marketing) brochure on AVS/Express**  
[http://www.avs.com/software/soft\\_t/avsxps.html](http://www.avs.com/software/soft_t/avsxps.html)

STM4 introduction - Mario Valle - 06/11/08



---

---

---

---

---

---

---

---

## Start STM4 (and 2" tutorial)

- Launch AVS/Express (with STM4 included):  

```
$ source /usr/local/userenv/express.csh  
$ express  
      (Linux)  
C:\> cd CSCSlib  
C:\CSCSlib> go.bat (Windows)
```
- Go to Libraries → STM4
- Then go to the rightmost column (Full Apps)
- Drag the MolDisplayApp block in the area below marked Applications (it is the Network Editor)
- In the window that pops up select the file format (e.g. PDB) and read a file.
- Mouse rotate. Middle Mouse Button+Shift: Zoom. +Ctrl: Pan. Reset with the  button.
- With the Modules drop down menu select Display Structure and change the molecule appearance.



---

---

---

---

---

---

---

---

## Start STM4 (special cases)

- Launch AVS/Express (Linux):  

```
$ ...setup env variables...  
$ express
```
- Launch AVS/Express (Windows):  
Start → AVS/Express Collection → Dev Edition
- Launch AVS/Express (Mac OSX):  
Start the X/Server (Applications/Utilities)  
then from the X terminal \$ express
- Special cases: `./go-viz ./go -nohw`



---

---

---

---

---

---

---

---

## Start with prebuilt MolDisplayApp

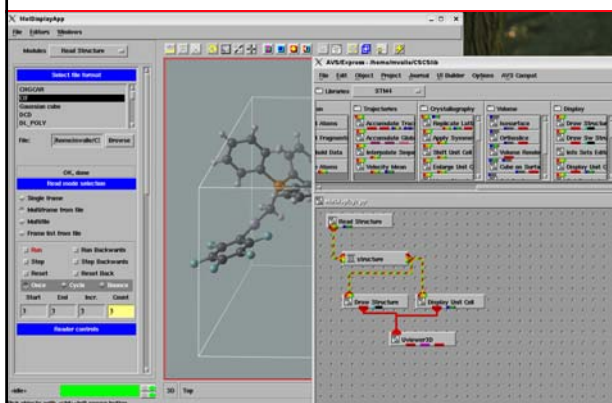

---

---

---

---

---

---

---

---

## Two static structures

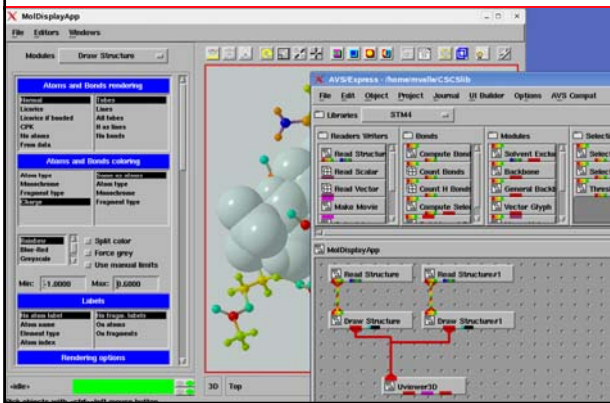

---

---

---

---

---

---

---

---

---

---

## Move to CrystalDisplay

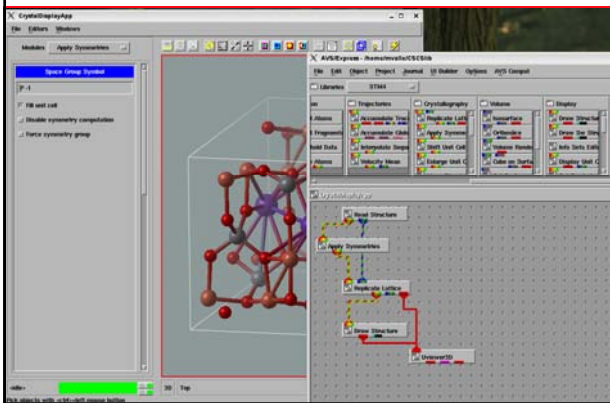

---

---

---

---

---

---

---

---

---

---

## Add tetrahedra

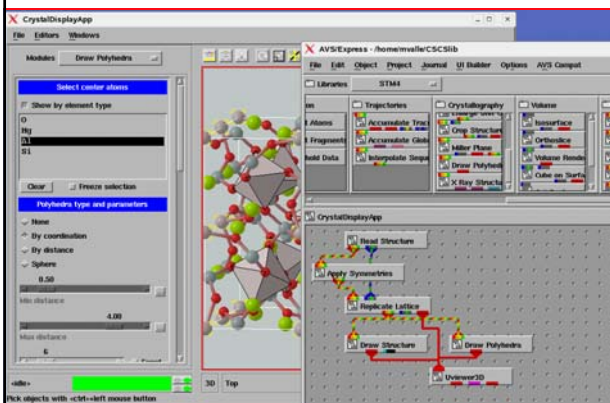

---

---

---

---

---

---

---

---

---

---

## Add title, logo and background

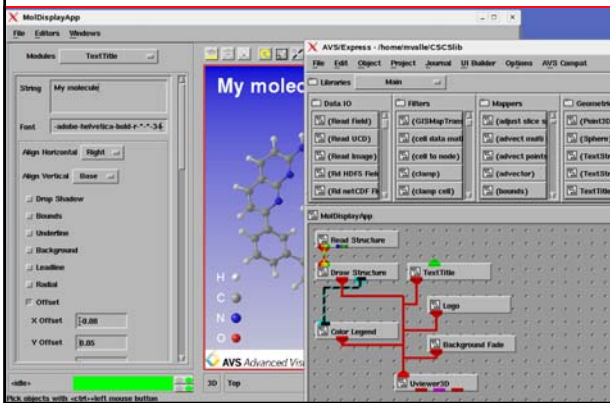

---

---

---

---

---

---

---

---

---

---

## Access volumetric data

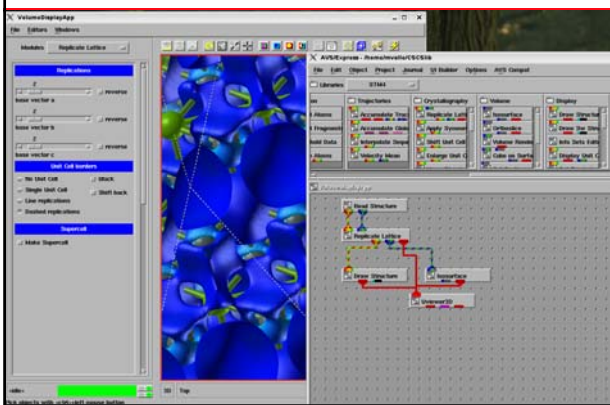

---

---

---

---

---

---

---

---

---

---

## Volume rendering

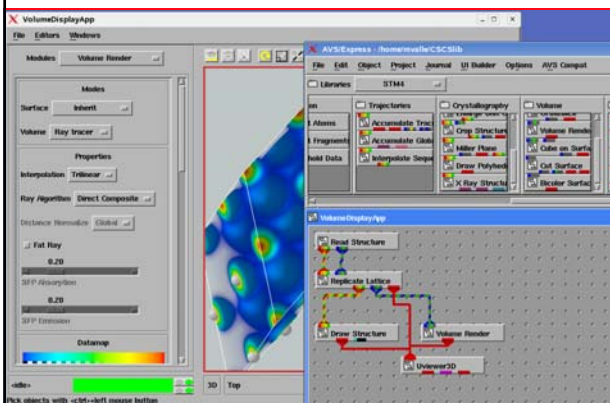

---

---

---

---

---

---

---

---

---

---

## Add protein backbone

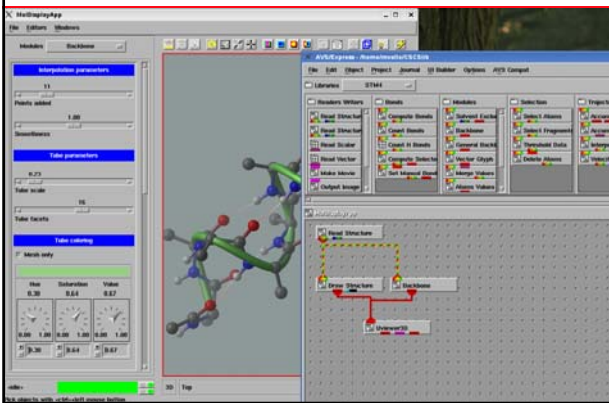

---

---

---

---

---

---

---

---

---

---

## Measure a structure

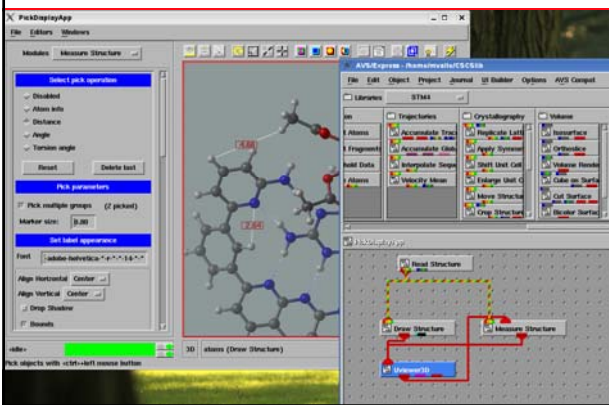

---

---

---

---

---

---

---

---

---

---

## STM4 module documentation

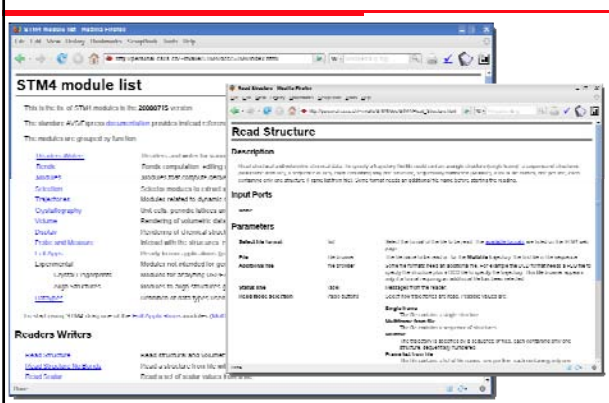

---

---

---

---

---

---

---

---

---

---

## AVS/Express modules with STM4

One of the advantage of STM4 is the possibility to mix AVS/Express standard modules with STM4 ones

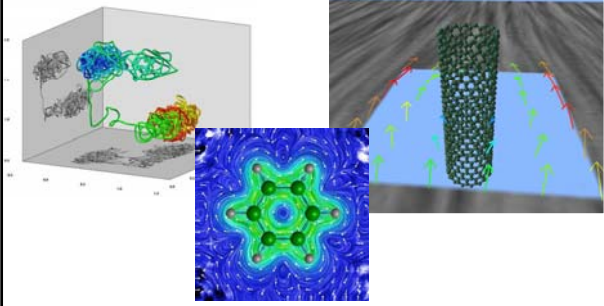

---

---

---

---

---

---

---

---

## AVS/Express modules in STM4

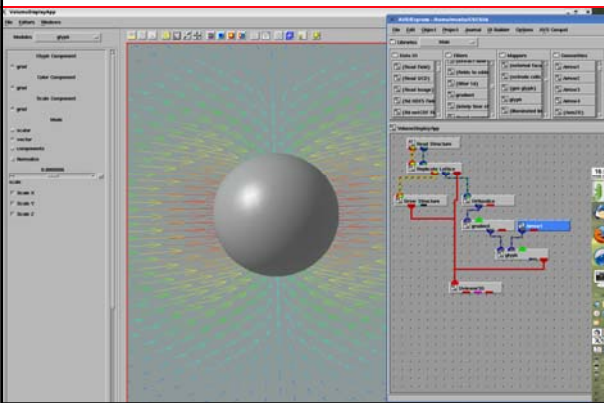

---

---

---

---

---

---

---

---

## STM4 to develop projects

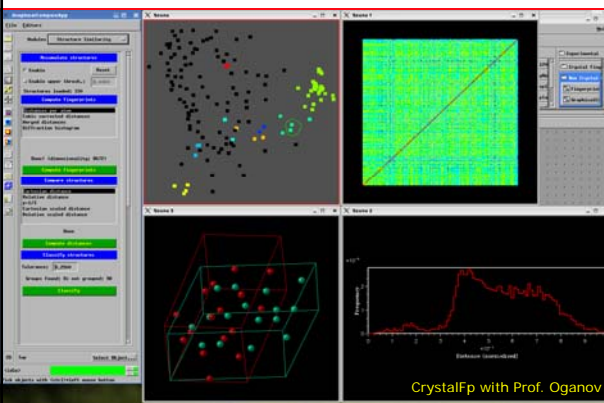

---

---

---

---

---

---

---

---

## To summarize

- With STM4 you can concentrate on the chemistry, not on the visualization tool
- STM4 needs your creative ideas to grow
- Try it with your data

---

---

---

---

---

---

---

---

## Agenda

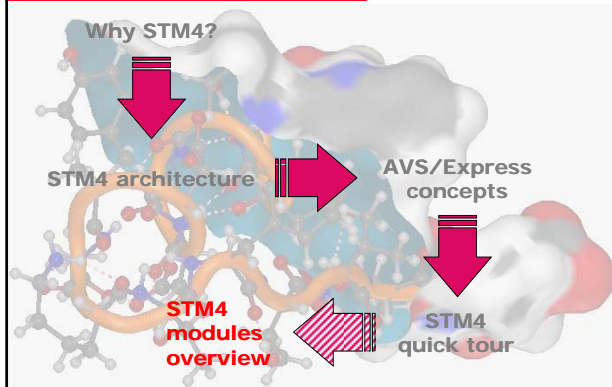

---

---

---

---

---

---

---

---

## STM4 modules in depth

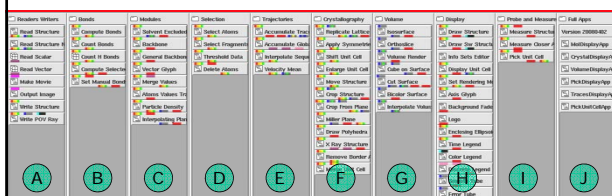

- Readers and writers: chemical formats and screenshots
- Bonds related modules: compute, count and edit
- Modules that compute various derived structures
- Atoms selection by various criteria
- Trajectory related modules
- Crystallography support modules: symmetries, replications, etc.
- Visualization of volumetric data like Gaussian cubes
- Structure display and related graphical objects
- Probe, interaction and measurements
- Ready to run applications (plus display of the STM4 version)

---

---

---

---

---

---

---

---

## Complete applications

Full Apps

Version 20080-402

- MolDisplayApp
- CrystalDisplayApp
- VolumeDisplayApp
- PickDisplayApp
- TracesDisplayApp
- PickUnitCellApp

- Ready to run applications
  - MolDisplayApp** Read and display a molecule.
  - CrystalDisplayApp** Read and display structures with symmetries and unit cell replication.
  - VolumeDisplayApp** Structure plus volumetric data
  - PickDisplayApp** Measure structure
  - TracesDisplayApp** Trace the motion of atoms
  - PickUnitCellApp** Redefine the molecule unit cell by corner picking and crops the structure inside the new unit cell.
- Plus the STM version string

---

---

---

---

---

---

---

---

---

---

## MolDisplayApp

---

---

---

---

---

---

---

---

---

---

## CrystalDisplayApp

---

---

---

---

---

---

---

---

---

---





## Display



- Rendering of chemical structures and other graphical objects.
  - **Draw Structure** and **Draw Sw Structure** Render structures
  - **Info Sets Editor** Edit render characteristics
  - **Display Unit Cell** Displays the borders of the unit cell.
  - **Set Rendering Mode** To change the rendering of only some atoms
  - **Axis Glyph** Display three arrows to mark the origin and the XYZ axis directions, or the unit cell abc vectors. The glyph could also be offset from the origin.
  - **Background Fade** Provide a colored backdrop for which you can set the four corners colors.
  - **Logo** Create a logo image to be added to a viewer.
  - **Enclosing Ellipsoid** Compute an ellipsoid that encloses the given set of atoms.
  - **Time Legend** Display a progress bar to show the current timestep or current time for an animated molecule trajectory.
  - **Color Legend** Display a legend for the structure representation colors.
  - **Discrete Legend** Color swatches for discrete data (eg. bond count)
  - **Smooth Tube** Create a tube that connect all the given points.
  - **Error Tube** Create a tube with a radius proportional to the values associated to the connected points.

---

---

---

---

---

---

---

---

---

---

## Display structure

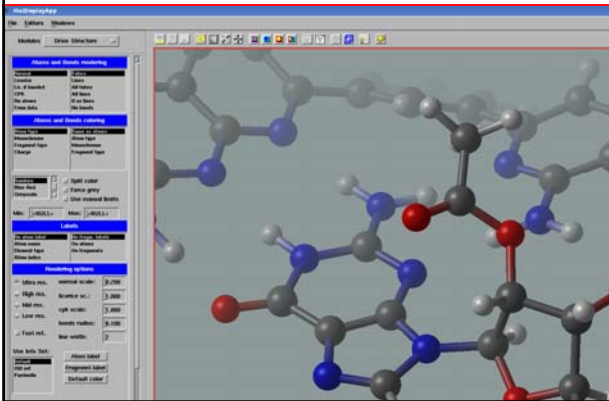

---

---

---

---

---

---

---

---

---

---

## Enclosing Ellipsoid

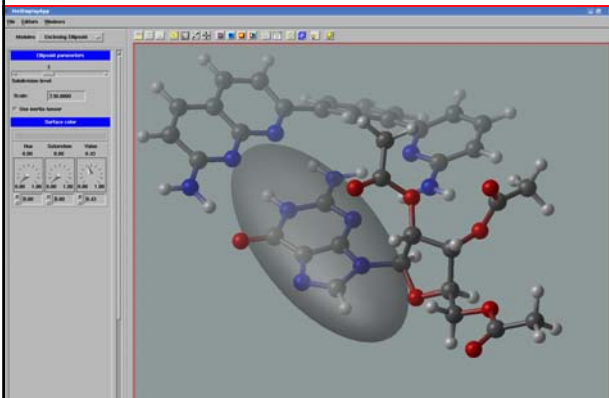

---

---

---

---

---

---

---

---

---

---

## Info Sets Editor

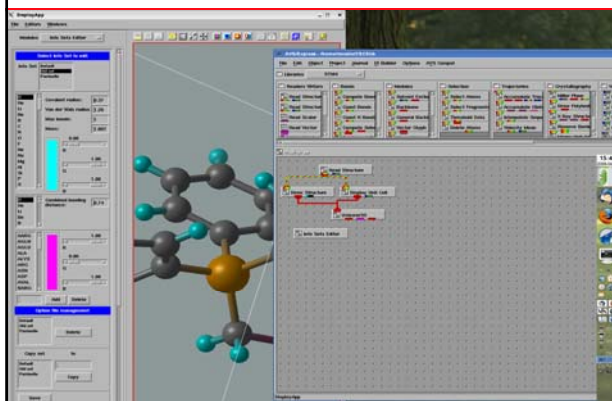

---

---

---

---

---

---

---

---

## Add title, logo and background

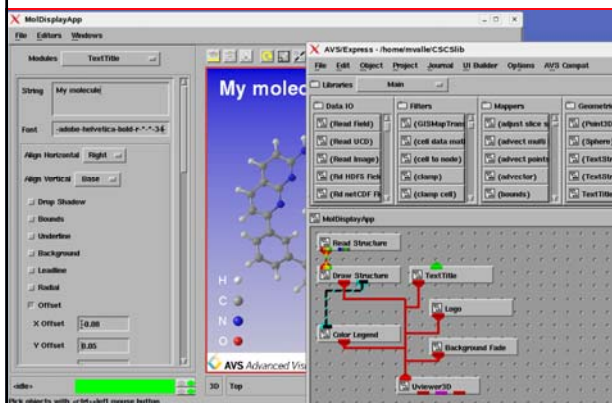

---

---

---

---

---

---

---

---

## Bonds



- Bonds computation, editing and management.
  - **Compute Bonds** Compute atomic bonds.
  - **Count Bonds** Add as atom data the atom's number of bonds.
  - **Count H Bonds** Count the number of H Bonds present in the input structure. The count is added to the structure global data.
  - **Compute Selected Bonds** Add bonds for each atom individually plus coordination tetrahedra
  - **Set Manual Bonds** Manually add bonds between atoms.

---

---

---

---

---

---

---

---

## Compute Selected Bonds

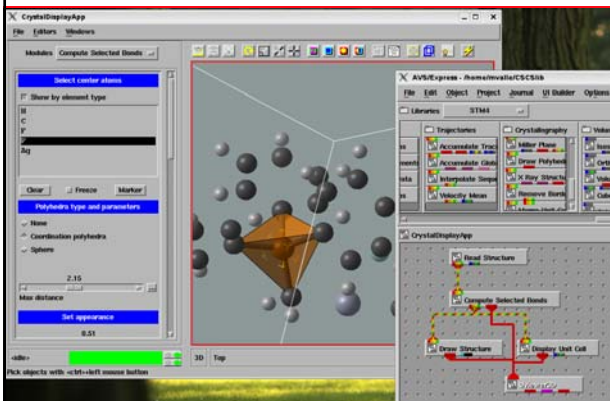

---

---

---

---

---

---

---

---

## Compute derived structures

Modules

- Solvent Excluded
- Backbone
- General Backbone
- Vector Glyph
- Merge Values
- Atoms Values Trasp
- Particle Density
- Interpolating Plane

- Modules that compute derived structures.
  - **Solvent Excluded Surface** Compute the molecule Solvent Excluded Surface.
  - **Backbone** Compute a protein backbone.
  - **General Backbone** Display a tube through user selected atoms.
  - **Vector Glyph** Display with arrows the vector data associated with a given structure.
  - **Merge Values** Add a new scalar or vector data to atoms, bonds or globally to the given structure.
  - **Atoms Values Trasp** Render atoms with transparency dependent on the associated scalar value
  - **Particle Density** Compute the average particle mass density using uniform binning.
  - **Interpolating Plane** Build the least square plane interpolating a set of picked atoms ( $n \geq 3$ ).

---

---

---

---

---

---

---

---

## Add protein backbone

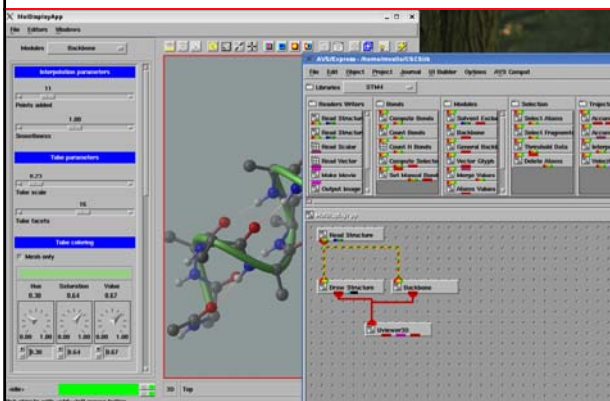

---

---

---

---

---

---

---

---

## Interactivity (probe & measure)



- Interact with the structures: measure and editing.
  - Measure Structure** Access information about and measure a displayed structure.
  - Measure Closer Atoms** Measure intra-atomic distances between a given atom and the surrounding ones in a given range.
  - Pick Unit Cell** Redefines the unit cell for the displayed structure by picking on four atoms.

---

---

---

---

---

---

---

---

## Measure a structure

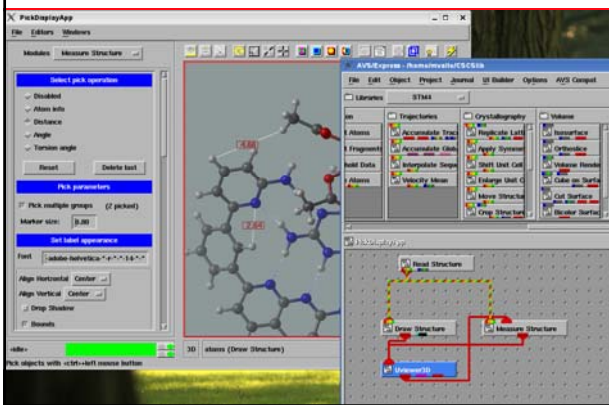

---

---

---

---

---

---

---

---

## Measure closer atoms

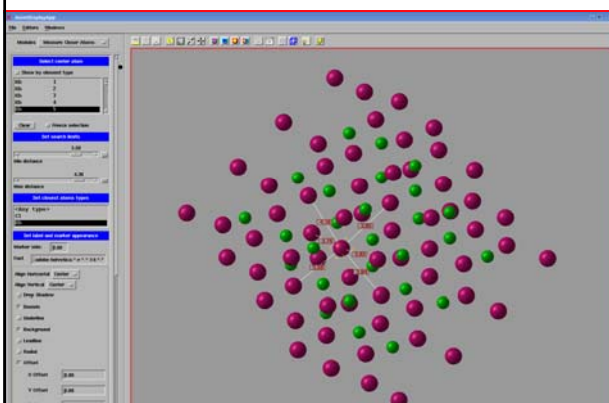

---

---

---

---

---

---

---

---

## Select subsets



- Selector modules to extract a subset of the atoms.
  - **Select Atoms** Select specific atoms.
  - **Select Fragments** Select specific structure fragments (i.e. residues).
  - **Threshold Data** Select atoms whose associated scalar value meets various criteria.
  - **Delete Atoms** Interactively delete atoms.

---

---

---

---

---

---

---

---

## Data threshold

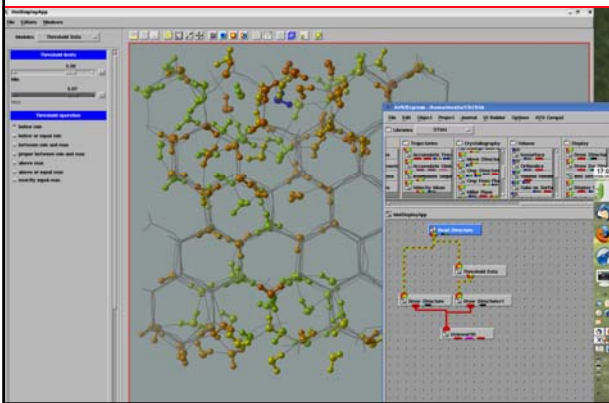

---

---

---

---

---

---

---

---

## Trajectories



- Modules related to dynamic data.
  - **Accumulate Traces** Accumulate traces (accumulated positions) for specific atoms in a sequence of time steps.
  - **Accumulate Global Data** Accumulate a global scalar data in a form suitable for charting.
  - **Interpolate Sequence** Linearly interpolate a given number of positions between each pair of timesteps.
  - **Velocity Mean** Compute the average particle velocity using uniform binning.

---

---

---

---

---

---

---

---

## Accumulate atoms traces

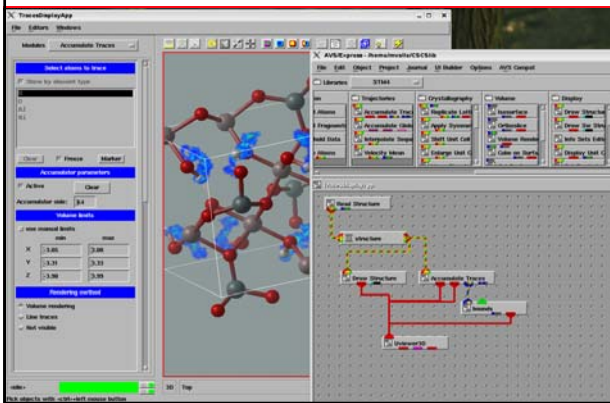

---

---

---

---

---

---

---

---

---

---

## Volumetric data support

**Volume**

- Isosurface
- Orthoslice
- Volume Render
- Cube on Surface
- Cut Surface
- Bicolor Surface
- Interpolate Volume

- Rendering of volumetric data like Gaussian cubes.
  - **Isosurface** Create an isosurface for a given scalar value.
  - **Orthoslice** Create an orthoslice for a given scalar value.
  - **Volume Render** Volumetric render of a scalar valued volume.
  - **Cube on Surface** Assign to a surface the values of the volume in which the surface is immersed in the positions occupied by the surface itself.
  - **Cut Surface** Cut a surface (eg. a Solvent Excluded Surface) with a plane.
  - **Bicolor Surface** Color a surface on one side with a user specified color leaving the other one with its original coloring.
  - **Interpolate Volume** Interpolate a given scalar volume adding points between original grid points.

---

---

---

---

---

---

---

---

---

---

## Volume rendering

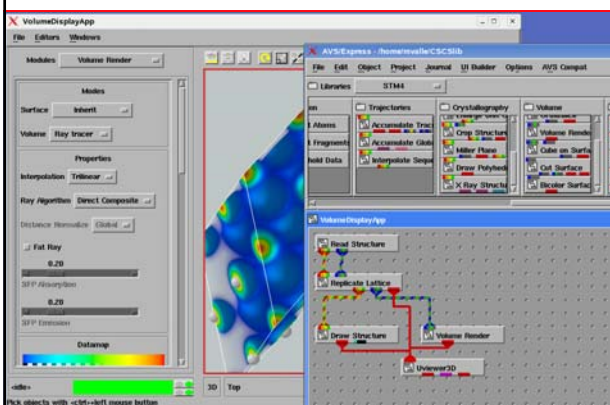

---

---

---

---

---

---

---

---

---

---



**End of a nice day...**

Lugano lake sunset



**Thank you!**

**BTW, I'm [mvalle@cscs.ch](mailto:mvalle@cscs.ch)**

---

---

---

---

---

---

---

---